

PROJECT NAME	JOB NO.	QUANTITY	ITEM NO
--------------	---------	----------	---------

# Air screen refrigerated wall case

MODEL **SWINB**



## General Information

Air screen upright refrigerated cases provide the ideal display solution for self-serve beverages and chilled prepackaged items without customer-side doors.

A curtain of refrigerated air directed across the open front efficiently seals off warmer ambient air. This allows better visibility, easy selection and loading, and eliminates maintenance problems with worn-out or ill-fitting doors.

Refcon Air Screen cases are attractive, quiet, and built from tough, easy-to-clean stainless steel and laminates. Standard 3500K interior lighting offers a bright, attention-getting display. Electronic temperature and defrost control and

digital temperature display makes it easy to keep products cold while using energy efficiently.

Available with self-contained or remote refrigeration. Leveling legs are standard. Choose from 6 lengths up to 12 ft (3.7m).

See below for available options, including rear loading doors, additional air flow patterns, and a choice of security door designs.

Airscreen refrigerated case Model SWINB with optional glass ends and additional shelves.

## Standard Features

- Stainless steel interior.
- (2) adjustable lighted 16 in. (40 cm) shelves.
- Mirror ends.
- Standard grade plastic laminate exterior (matte finish.)
- 3500K fluorescent tube lights.
- Condensate evaporator (self-contained units).
- Digital temperature display.
- Electronic temperature and defrost control (self-contained units).
- Structural steel base with leveling legs.

## Options

- Glass ends
- Stainless steel exterior
- 4 in. exhaust wall standoffs
- Black powder painted interior
- White powder painted interior
- Custom powder painted interior
- Continuous cases
- Remote refrigeration temperature control package
- One way mirror rear load door
  - Rear door locks
- Additional shelves with lights
- LED lighting
- Pull down plastic energy shade
- Sound reduction package
- Power cord and plug
- 1-year labor warranty
- 5-year compressor warranty

## Security Options

- Roll down security shutter
- Removable Lexan® security panels
- Choice of alternative air flow patterns—see air screen airflow options sheet for details.

Designed to operate in air conditioned space maintained at 75°F (24°C) and 55% relative humidity. Continuing product improvement may subject specifications to change without notice.

CUSTOMER NAME	
<input type="checkbox"/> APPROVED <input type="checkbox"/> APPROVED AS NOTED <input type="checkbox"/> RESUBMIT	
AUTHORIZED SIGNATURE	DATE



**Refcon Inc.**  
 335 Chestnut Street Norwood, NJ 07648 USA  
 Tel: (201) 750-5060  
 Fax: (201) 750-5066  
 e-mail: sales@refconcase.com  
**www.refconcase.com**

# Air screen refrigerated wall case

MODEL **SWINB**

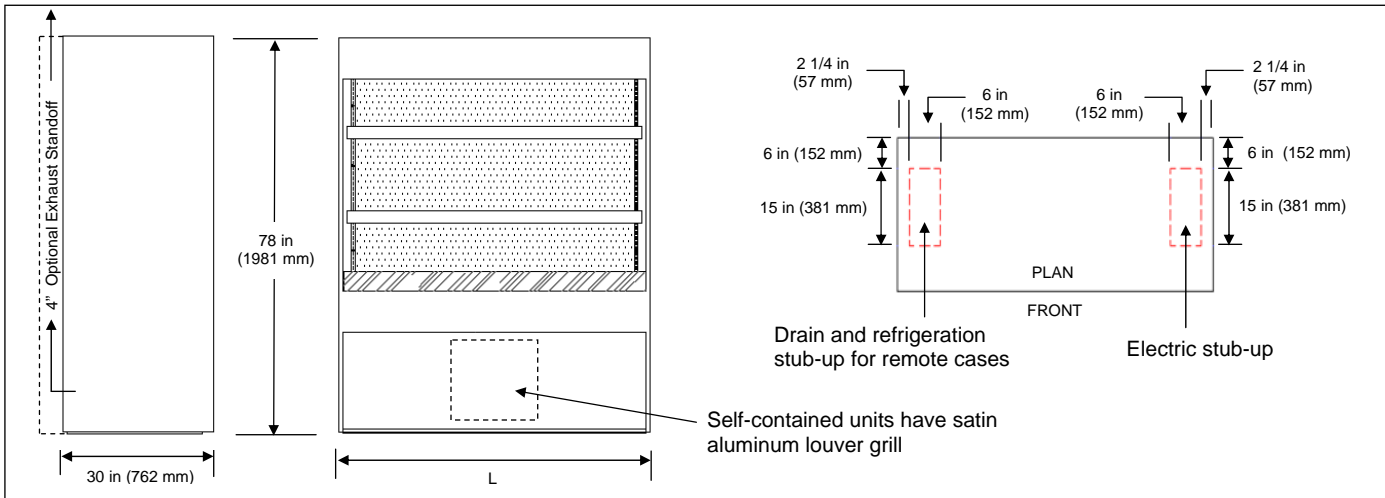

	Model	Dimensions		Required Refrigeration	Crated Weight	
		(L x D x H) in	(L x D x H) mm		lb	kg
Self-contained Refrigeration	SWINBS036	37 1/2 x 30 x 78	953 x 762 x 1981	1/2 HP	500	227
	SWINBS048	49 1/2 x 30 x 78	1257 x 762 x 1981	3/4 HP	600	272
	SWINBS060	61 1/2 x 30 x 78	1562 x 762 x 1981	1 HP	750	341
	SWINBS072	73 1/2 x 30 x 78	1867 x 762 x 1981	1 HP	900	409
	SWINBS096	97 1/2 x 30 x 78	2477 x 762 x 1981	1 1/2 HP	1200	545
Remote Refrigeration (R404a)	SWINBR036	37 1/2 x 30 x 78	953 x 762 x 1981	4200 @ +15	400	182
	SWINBR048	49 1/2 x 30 x 78	1257 x 762 x 1981	5600 @ +15	500	227
	SWINBR060	61 1/2 x 30 x 78	1562 x 762 x 1981	7000 @ +15	700	318
	SWINBR072	73 1/2 x 30 x 78	1867 x 762 x 1981	8400 @ +15	800	363
	SWINBR096	97 1/2 x 30 x 78	2477 x 762 x 1981	11200 @ +15	900	409
	SWINBR144	145 1/2 x 30 x 78	3683 x 762 x 1981	16800 @ +15	1300	590

Laboratory certifications



Electrical	Model	Volts	Phase	Cycle/Hz	Watts	MCA	Plug type (optional)
Self-contained Refrigeration	SWINBS036	120	1	60	2949	27	NEMA L5-30P
	SWINBS048	120-208	1	60	2630	17	NEMA L14-20P
	SWINBS060	120-208	1	60	3228	21	
	SWINBS072	120-208	1	60	3786	25	NEMA L14-30P
	SWINBS096	120-208	1	60	4445	29	
Remote Refrigeration (R404a)	SWINBR036	120	1	60	233	3	NEMA 5-15P
	SWINBR048	120	1	60	257	3	
	SWINBR060	120	1	60	278	3	
	SWINBR072	120	1	60	462	5	
	SWINBR096	120	1	60	515	6	
	SWINBR144	120	1	60	609	6	

NOTE: 1) Floor drain required for remote units. 2) See air screen airflow options sheet. 3) Black laminate at top and rear.

Please specify exterior finish:



Refcon Inc.

Tel: (201) 750-5060  
www.refconcase.com