

PROJECT NAME	JOB NO.	QUANTITY	ITEM NO
--------------	---------	----------	---------

Deli service refrigerated case

Matches Henny Penny HMR profiles



- MODEL **HMR3** 3 well
HMR4 4 well
HMR5 5 well
HMR6 6 well
HMR7 7 well

Tempered front and end glass provides 100 percent product visibility and matches four different Henny Penny glass profiles. Front glass lifts and closes easily, giving employees comfortable access for loading and cleaning.

The Refcon refrigerated HMR is available in five standard lengths, corresponding with the Henny Penny HMR product line. (See separate data sheet.) Units can be ordered for remote refrigeration or with self-contained condensing units.

Refcon full-service refrigerated cases are built from tough, easy-to-clean stainless steel and tempered glass. They can be supplied individually or integrated into a custom deli or cafeteria case line that includes a variety of heated, refrigerated, dry and self-service cases, along with custom bases and millwork to match your interior design.

Matching HMR service refrigerated deli case Model HMR shown with curved glass profile on base unit by Henny Penny.

General Information

Refcon offers this refrigerated deli service case in a sleek contemporary design that matches Henny Penny HMR hot case profiles.

The HMR series extends the flexibility and performance of Henny Penny heated merchandisers with the perfect matching system from Refcon for displaying and serving cold deli foods.

Standard Features

- Tempered lift-up front glass.
- Please specify Henny Penny matching glass profile:
 - Curved
 - Straight
 - Vision
 - Advantage
- Lexan® rear sliding doors.
- Tempered glass ends.
- Stainless steel interior and exterior.
- Air over/under refrigeration system.
- 3500K fluorescent top lights.
- Electronic temperature and defrost control (self-contained units).
- Air-cooled condensing units (self-contained units).
- 6 ft power cord and plug (self-contained units.)
- Separate ON/OFF switch (self-contained units.)
- Accepts 4 in. steam table pans, 1 full-size and 1 third-size pan per well or equivalent combination.
- All cases are ETL safety and sanitation listed.

Options

- Remote refrigeration temperature control package
- 1-year labor warranty
- 5-year compressor warranty

Designed to operate in air conditioned space maintained at 75°F (24°C) and 55% relative humidity. Continuing product improvement may subject specifications to change without notice.

CUSTOMER NAME	
<input type="checkbox"/> APPROVED	<input type="checkbox"/> APPROVED AS NOTED
<input type="checkbox"/> RESUBMIT	
AUTHORIZED SIGNATURE	DATE



Refcon Inc.
 335 Chestnut Street Norwood, NJ 07648 USA
 Tel: (201) 750-5060
 Fax: (201) 750-5066
 e-mail: sales@refconcase.com
www.refconcase.com

Deli service refrigerated case

Matches Henny Penny HMR profiles

MODEL **HMR3** 3 well
HMR4 4 well
HMR5 5 well
HMR6 6 well
HMR7 7 well

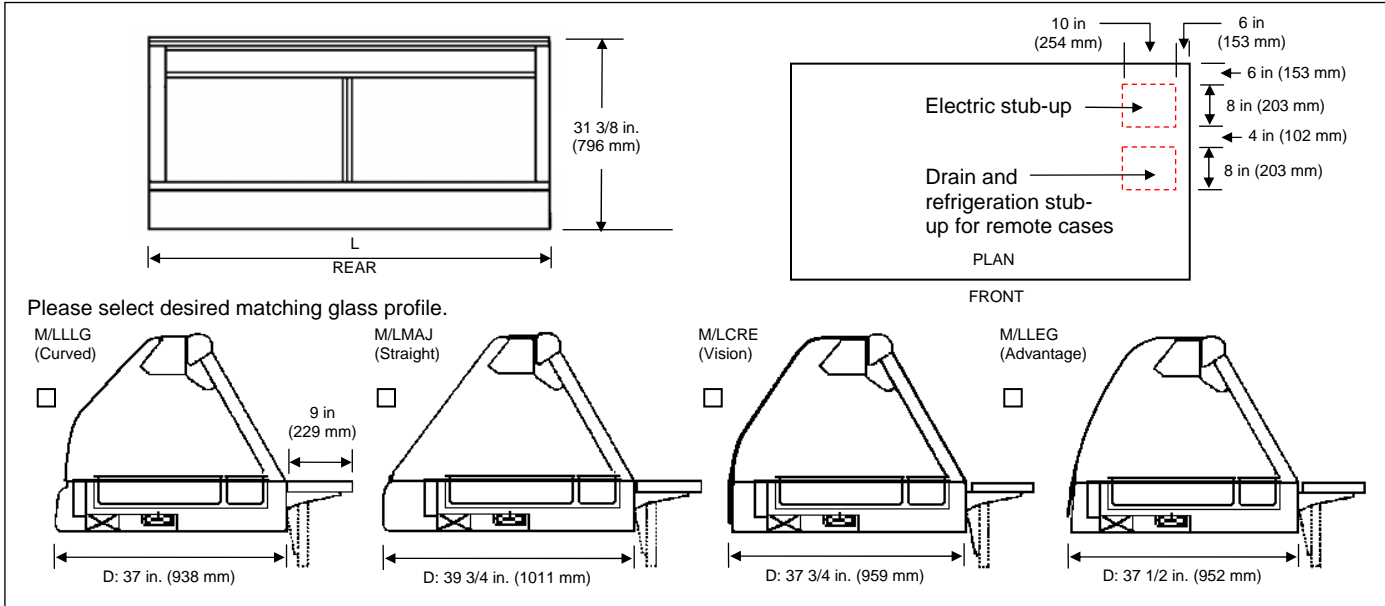

See separate installation detail sheet.

	Model (Select profile)	Dimensions		Refrigeration requirements	Crated Weight	
		(L x D x H) in	(L x D x H) mm		lb	kg
Self-contained Refrigeration	DS043-HMR3	43 1/4 x D x 31 3/8	1099 x D x 796	1/3 HP	401	182
	DS055-HMR4	56 1/4 x D x 31 3/8	1429 x D x 796	1/2 HP	510	259
	DS069-HMR5	69 1/4 x D x 31 3/8	1759 x D x 796	1/2 HP	605	274
	DS082-HMR6	82 1/4 x D x 31 3/8	2089 x D x 796	1/2 HP	734	333
	DS095-HMR7	95 1/4 x D x 31 3/8	2419 x D x 796	3/4 HP	827	375
Remote Refrigeration (R404a)	DR043-HMR3	43 1/4 x D x 31 3/8	1099 x D x 796	2400 BTU @ +15	371	168
	DR055-HMR4	56 1/4 x D x 31 3/8	1429 x D x 796	3000 BTU @ +15	470	213
	DR069-HMR5	69 1/4 x D x 31 3/8	1759 x D x 796	3800 BTU @ +15	555	252
	DR082-HMR6	82 1/4 x D x 31 3/8	2089 x D x 796	4500 BTU @ +15	674	306
	DR095-HMR7	95 1/4 x D x 31 3/8	2419 x D x 796	5200 BTU @ +15	757	343

Electrical

	Model	Volts	Phase	Cycle/Hz	Watts	MCA	Plug type	
Self-contained Refrigeration	DS043-HMR3	120	1	60	910	10	NEMA 5-15P	
	DS055-HMR4	120	1	60	1294	14		
	DS069-HMR5	120	1	60	1441	16	NEMA L5-20P	
	DS082-HMR6	120	1	60	2968	20	NEMA L5-30P	
	DS095-HMR7	120-208	1	60	3011	21		
Remote Refrigeration (R404a)	DR043-HMR3	120	1	60	187	2	NEMA 5-15P	
	DR055-HMR4	120	1	60	200	2		
	DR069-HMR5	120	1	60	226	2		
	DR082-HMR6	120	1	60	236	2		
	DR095-HMR7	120	1	60	260	2		

Laboratory
certifications



NOTE: Floor drain required for all units.



Refcon Inc.
 Tel: (201) 750-5060
www.refconcase.com