

PROJECT NAME	JOB NO.	QUANTITY	ITEM NO
--------------	---------	----------	---------

Deli Eclipse corner units

MODEL **LECLD-1C**
LECLD-0C



Deli Eclipse refrigerated serving counter corner units

Employees will appreciate the Eclipse, too, for its easy access for serving, restocking or cleaning.

Large, curved, lift-up glass panels maximize visibility and draw customers to do more than window shop. Eclipse's smooth lines combine the ultimate in service and self-service operations.

Refcon refrigerated serving counters are built from tough, easy-to-clean laminates and stainless steel. 3500K interior lighting offers a bright, attention-getting display. Electronic controls and digital temperature display makes it easy to keep products cold while using energy efficiently.

A wide choice of options are available to help you customize your Refcon Eclipse, including glass or mirror ends and lower front decorative lighting.

General Information

Explore the layout possibilities for Refcon's Eclipse refrigerated serving counters with inside and outside corner units. Dramatic curving "corners" deliver a visually exciting presentation for your cold deli offerings.

Standard Features

- Lift-up curved glass.
- Interior stainless steel deck and rear plenum.
- Exterior standard grade plastic laminate (matte finish).
- 3500K fluorescent lights.
- Digital temperature display.
- Remote refrigeration (R404a)

Options

- Stainless steel exterior
- Black interior
- Glass ends
- One-way mirror ends
- Tiered display insert
 - 1 step for 2-level display
 - 2 steps for 3-level display
- Scale platform
- 18 in. (457 mm) paper roll holder
- Front cart bumper
- Lower front decorative lighting
- LED lighting
- Continuous case line up

- Remote refrigeration temperature control package
- GFI convenience outlet 15A (to J box)
- Power cord and plug

Designed to operate in air conditioned space maintained at 75°F (24°C) and 55% relative humidity. Continuing product improvement may subject specifications to change without notice.

CUSTOMER NAME	
<input type="checkbox"/> APPROVED	<input type="checkbox"/> APPROVED AS NOTED
<input type="checkbox"/> RESUBMIT	
AUTHORIZED SIGNATURE	DATE



Refcon Inc.
335 Chestnut Street Norwood, NJ 07648 USA
Tel: (201) 750-5060
Fax: (201) 750-5066
e-mail: sales@refconcase.com
REFCON™ www.refconcase.com

PROJECT

ITEM NO

Deli Eclipse

MODEL **LECLD-IC**
LECLD-OC

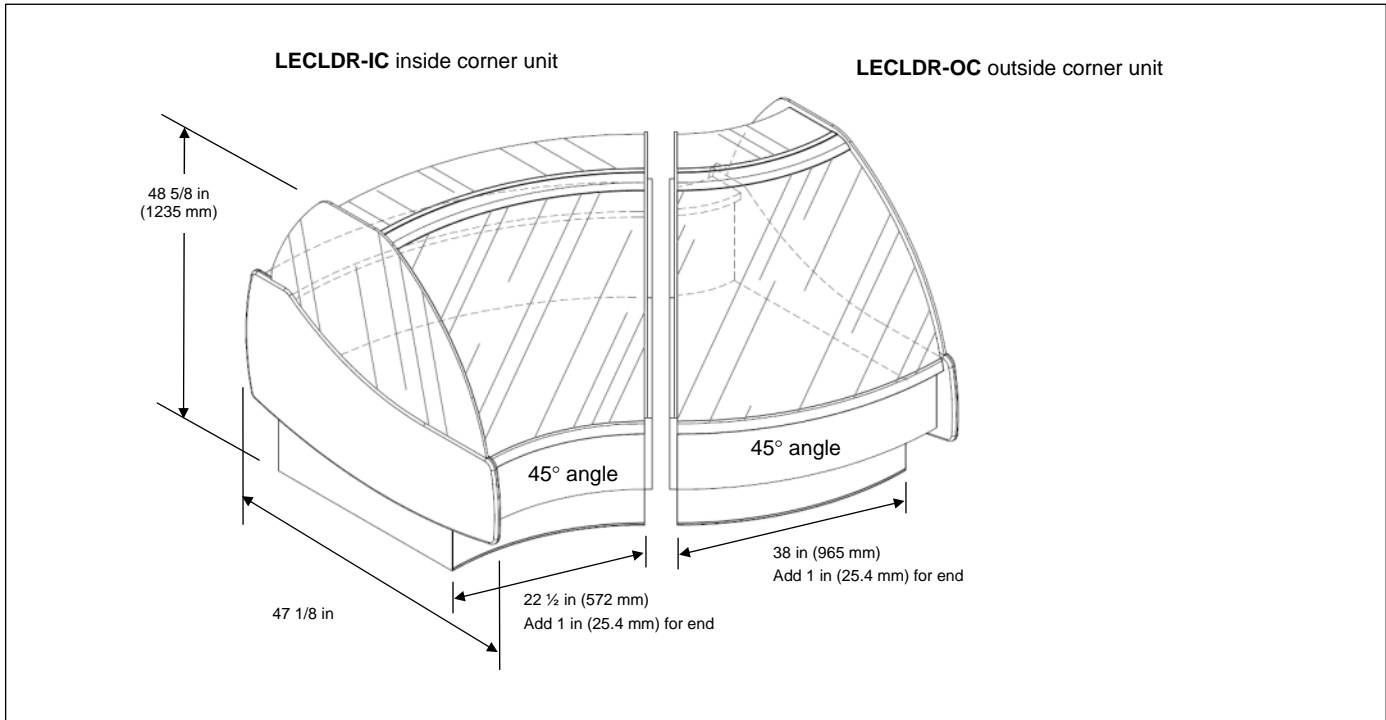

Model	Dimensions		Refrigeration requirements	Crated Weight	
	(L x D x H) in	(L x D x H) mm		lb	kg
LECLDR-IC	Contact Refcon for layout		1500 @ +15	845	384
LECLDR-OC			2000 @ +15	780	354

Laboratory certifications



Note: Add 1 in (25.4 mm) to L dimension for each end.

Electrical

Model	Volts	Phase	Cycle/Hz	Watts	Amps	Plug type (optional)
LECLDR-IC	120	1	60	240	2.0	NEMA 5-15P 
LECLDR-OC	120	1	60	240	2.0	

NOTE: Floor drain required.

Please specify exterior finish:



Refcon Inc.

Tel: (201) 750-5060
www.refconcase.com