

PROJECT NAME	JOB NO.	QUANTITY	ITEM NO
--------------	---------	----------	---------

Air screen self-service island case

MODEL SCASD

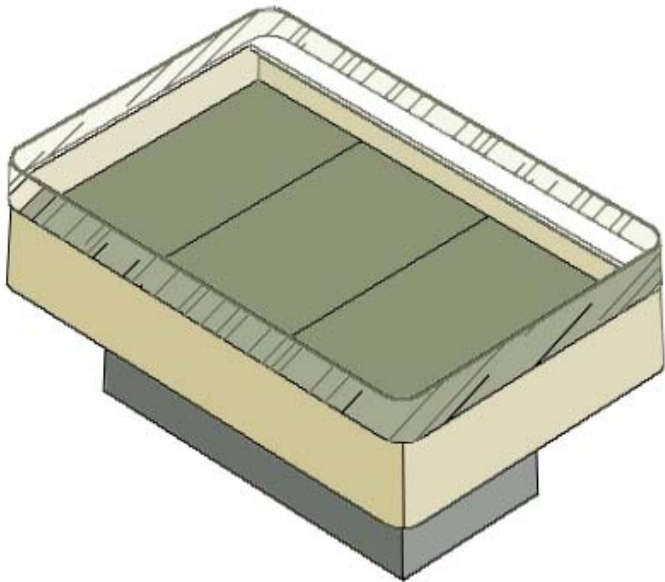

Air screen self-service island case Model SCASD

General Information

Air screen self-service island cases let customers grab their favorite chilled dairy, juice, beverage, or prepackaged salads and desserts from a convenient island display.

A curtain of refrigerated air flows across the open case, efficiently sealing off warmer ambient air.

Stainless steel interior and standard matte laminate are attractive, durable and easy to keep clean.

Refcon airtscreen islands feature electronic temperature and defrost control and digital temperature display. Adjustable leveling legs are standard.

Available with self-contained or remote refrigeration. Choose from 4 lengths up to 12 ft (3.7m).

Standard Features

- Stainless steel interior
- Standard grade plastic laminate exterior (matte finish).
- Condensate evaporator (self-contained units).
- Digital temperature display
- Electronic temperature and defrost control (self-contained units).
- Structural steel base with adjustable legs.
- Perimeter cart bumper.

Options

- Stainless steel exterior
- Black powder painted interior
- White powder painted interior
- Custom powder painted interior
- Sound reduction package
- Remote refrigeration control package
- Power cord and plug
- 1-year labor warranty
- 5-year compressor warranty

Designed to operate in air conditioned space maintained at 75°F (24°C) and 55% relative humidity. Continuing product improvement may subject specifications to change without notice.

CUSTOMER NAME	
<input type="checkbox"/> APPROVED	<input type="checkbox"/> APPROVED AS NOTED <input type="checkbox"/> RESUBMIT
AUTHORIZED SIGNATURE	DATE



REFCON™

Refcon Inc.

335 Chestnut Street Norwood, NJ 07648 USA

Tel: (201) 750-5060

Fax: (201) 750-5066

e-mail: sales@refconcase.com

www.refconcase.com

PROJECT

ITEM NO

Air screen self-service island case

MODEL SCASD

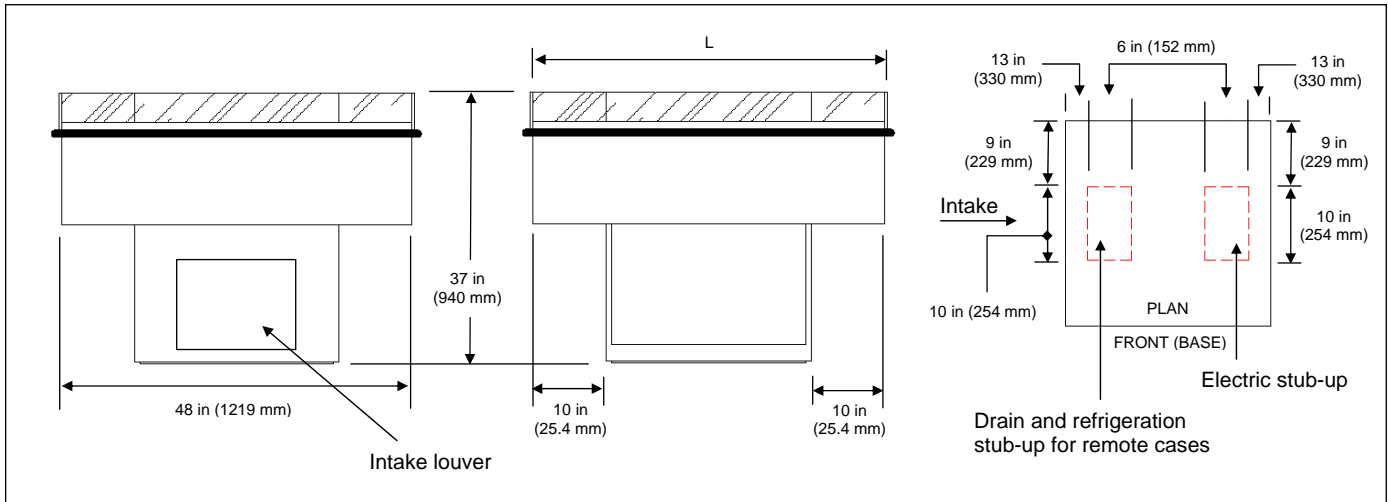





	Model	Dimensions		Refrigeration requirements	Crated Weight	
		(L x D x H) in	(L x D x H) mm		lb	kg
Self-contained Refrigeration	SCASDS048	48 x 48 x 37	1219 x 1219 x 940	1/3 HP	383	174
	SCASDS072	72 x 48 x 37	1829 x 1219 x 940	1/2 HP	575	261
	SCASDS096	96 x 48 x 37	2438 x 1219 x 940	3/4 HP	766	348
	SCASDS144	144 x 48 x 37	3658 x 1219 x 940	1 HP	1150	522
Remote Refrigeration (R404a)	SCASDR048	48 x 48 x 37	1219 x 1219 x 940	2400 @ +15	350	159
	SCASDR072	72 x 48 x 37	1829 x 1219 x 940	3600 @ +15	525	238
	SCASDR096	96 x 48 x 37	2438 x 1219 x 940	4800 @ +15	700	318
	SCASDR144	144 x 48 x 37	3658 x 1219 x 940	7200 @ +15	1050	477

Laboratory certifications



Electrical

	Model	Volts	Phase	Cycle/Hz	Watts	MCA	Plug type (optional)
Self-contained Refrigeration	SCASDS048	120	1	60	2040	17	NEMA L5-20P 
	SCASDS072	120	1	60	2880	24	NEMA L5-30P 
	SCASDS096	120-208	1	60	3012	19	NEMA L14-20P 
	SCASDS144	120-208	1	60	3589	23	NEMA L14-30P 
Remote Refrigeration (R404a)	SCASDR048	120	1	60	120	1	NEMA 5-15P 
	SCASDR072	120	1	60	120	1	
	SCASDR096	120	1	60	240	2	
	SCASDR144	120	1	60	240	2	

NOTE: Floor drain required for remote units.

Please specify exterior finish:



Refcon Inc.

Tel: (201) 750-5060
www.refconcase.com