

PROJECT NAME	JOB NO.	QUANTITY	ITEM NO
--------------	---------	----------	---------

Cafeteria self-service dry case

MODEL M/SMASDD



Cafeteria self-service dry case, Model M/SMASDD.

General Information

Refcon cafeteria self-service cases offer contemporary design in a well-built, highly functional case. The Refcon self-service case features a stainless steel deck and two glass shelves with individual lift-up Lexan® doors for front access to all three display levels. Fluorescent

lighting, Lexan® sliding rear doors and Lexan® end panels are standard.

Refcon M/SMASDD models are available in three standard lengths and are often specified as “drop-in” items, ready to install directly into your counters.

We can integrate the self-serve dry case into a complete, custom cafeteria counter line with a variety of dry, heated, refrigerated and self-service cases according to designers specifications.

In addition, we offer several contemporary design concepts, such as “floating counters” that use pedestal bases to create an open look. Everything you want and need, from the basics to the exotic, from one trusted source.

Standard Features

- Curved Lexan® top with Lexan® lift-up doors for customer access.
- Stainless steel deck.
- Two glass shelves.
- Lexan® ends.
- Lexan® rear sliding doors.
- 3500K fluorescent lights.
- 6 ft. power cord and plug.

Options

- Custom base counter
- 1-year labor warranty

Designed to operate in air conditioned space maintained at 75°F (24°C) and 55% relative humidity. Continuing product improvement may subject specifications to change without notice.

CUSTOMER NAME	
<input type="checkbox"/> APPROVED	<input type="checkbox"/> APPROVED AS NOTED <input type="checkbox"/> RESUBMIT
AUTHORIZED SIGNATURE	DATE



Refcon Inc.
 335 Chestnut Street Norwood, NJ 07648 USA
 Tel: (201) 750-5060
 Fax: (201) 750-5066
 e-mail: sales@refconcase.com
REFCON™ www.refconcase.com

PROJECT	ITEM NO
---------	---------

Cafeteria self-service dry case

MODEL M/SMASDD

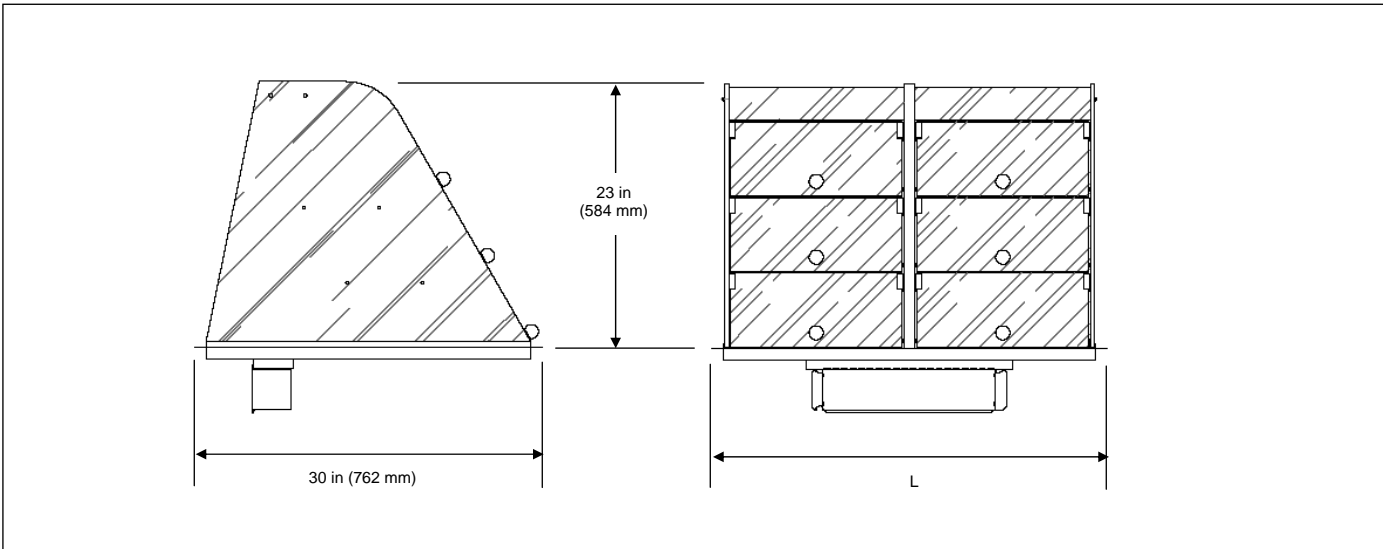

Model	Dimensions (drop-in version)		Lift-up Doors Sections/Doors	Crated Weight	
	(L x D x H) in	(L x D x H) mm		lb	kg
M/SMASDD032	34 1/4 x 30 x 23	1022 x 762 x 584	2/6	250	114
M/SMASDD048	50 3/4 x 30 x 23	1324 x 762 x 584	3/9	325	148
M/SMASDD065	67 x 30 x 23	1524 x 762 x 584	4/12	375	170

Laboratory certifications



Clearances: 6 in. (152 mm) below deck required.

Cutout: Subtract 1 1/2 in. (38 mm) from length and width dimensions.

Electrical

Model	Volts	Phase	Cycle/Hz	Watts	MCA	Plug type
M/SMASDD032	120	1	60	165	2	NEMA 5-15P 
M/SMASDD048	120	1	60	188	2	
M/SMASDD065	120	1	60	218	3	

Please specify exterior finish:



Refcon Inc.

Tel: (201) 750-5060
www.refconcase.com